

Quantum measurements

Measurements of light

QRATE

Roman Shakhovoy

КАНОНИЧЕСКОЕ КВАНТОВАНИЕ: гармонический осциллятор

$$H = \frac{p^2}{2m} + \frac{\kappa x^2}{2} \quad \text{– полная энергия системы (функция Гамильтона)}$$

Уравнения движения

$$\frac{dx}{dt} = \frac{\partial H}{\partial p}, \quad \frac{dp}{dt} = -\frac{\partial H}{\partial x}$$

$$\begin{cases} \frac{dx}{dt} = \frac{p}{m} \\ \frac{dp}{dt} = -\kappa x \end{cases} \rightarrow \begin{cases} x(t) = x(0) \cos \omega t + \frac{1}{m\omega} p(0) \sin \omega t \\ p(t) = p(0) \cos \omega t - m\omega x(0) \sin \omega t \end{cases}$$

$$\omega = \sqrt{\kappa/m} \quad \text{– собственная частота колебаний}$$

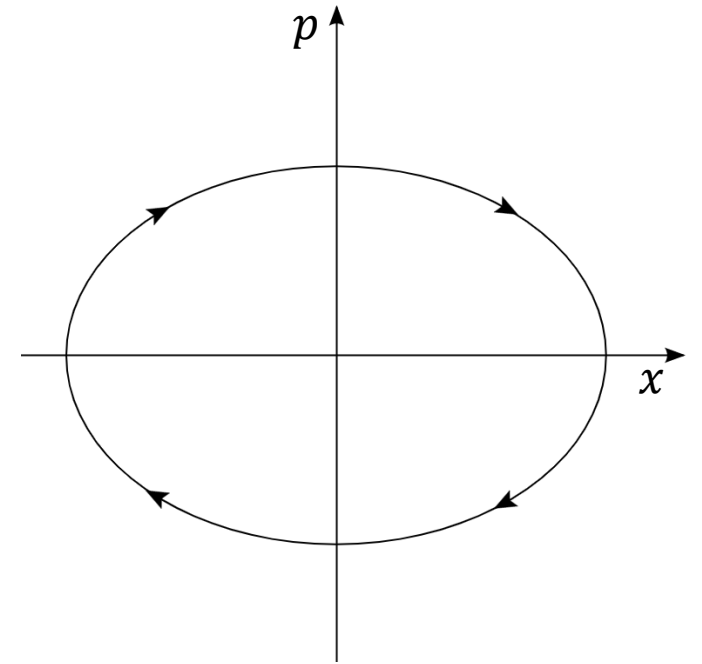

КАНОНИЧЕСКОЕ КВАНТОВАНИЕ: гармонический осциллятор

$$\hat{H} = \frac{\hat{p}^2}{2m} + \frac{m\omega^2 \hat{x}^2}{2} \quad \text{– полная энергия системы (гамильтониан)}$$

Уравнение
движения

$$\hat{H}|\psi\rangle = E|\psi\rangle$$

$|\psi\rangle$ – вектор состояния в гильбертовом пространстве

$\psi(x) = \langle x|\psi\rangle$ – волновая функция состояния $|\psi\rangle$ в координатном представлении

$$\psi_n(x) = \frac{1}{\sqrt{2^n n!}} \left(\frac{m\omega}{\pi\hbar}\right)^{1/4} e^{-\frac{m\omega x^2}{2\hbar}} H_n\left(\sqrt{\frac{m\omega}{\hbar}}x\right)$$

$$E_n = \hbar\omega\left(n + \frac{1}{2}\right) \quad n = 0, 1, 2, \dots$$

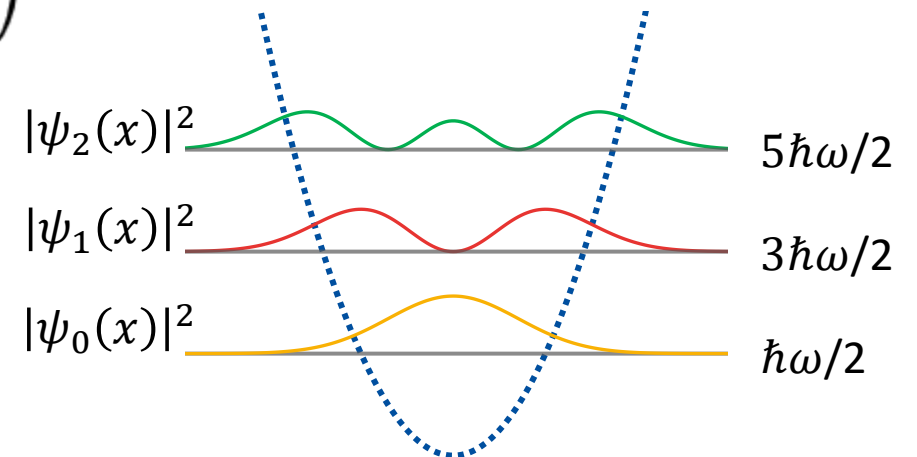

КАНОНИЧЕСКОЕ КВАНТОВАНИЕ: гармонический осциллятор

Формализм лестничных операторов

$$\hat{H} = \frac{\hat{p}^2}{2m} + \frac{m\omega^2 \hat{x}^2}{2}$$

$$\hat{a} = \sqrt{\frac{m\omega}{2\hbar}} \left(\hat{x} + \frac{i}{m\omega} \hat{p} \right) \quad \hat{a}^\dagger = \sqrt{\frac{m\omega}{2\hbar}} \left(\hat{x} - \frac{i}{m\omega} \hat{p} \right)$$

$\hat{n} = \hat{a}^\dagger \hat{a}$ – оператор числа квантов



$$\hat{H} = \hbar\omega \left(\hat{n} + \frac{1}{2} \right)$$

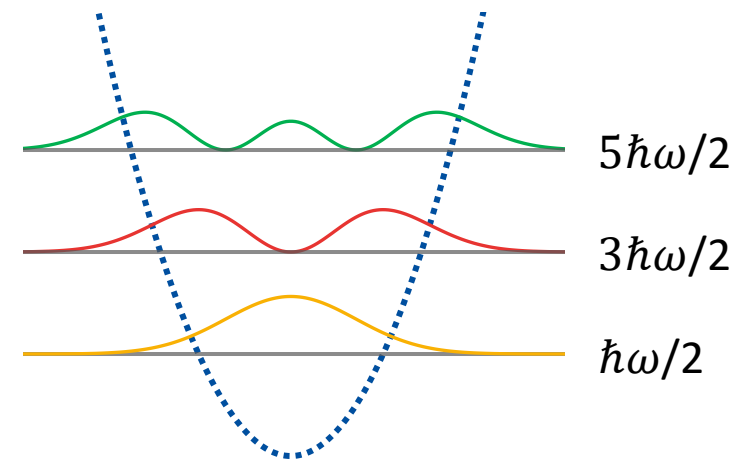

КАНОНИЧЕСКОЕ КВАНТОВАНИЕ: гармонический осциллятор

Формализм лестничных операторов

$$\hat{H} = \hbar\omega \left(\hat{n} + \frac{1}{2} \right)$$

Собственные состояния гамильтониана гармонического осциллятора называются *фоковскими* состояниями $|n\rangle$:

$$\hat{H}|n\rangle = \hbar\omega \left(n + \frac{1}{2} \right) |n\rangle$$

или

$$\hat{n}|n\rangle = n|n\rangle$$

$$\hat{a}|n\rangle = \sqrt{n}|n-1\rangle \quad \hat{a}^+|n\rangle = \sqrt{n+1}|n+1\rangle$$

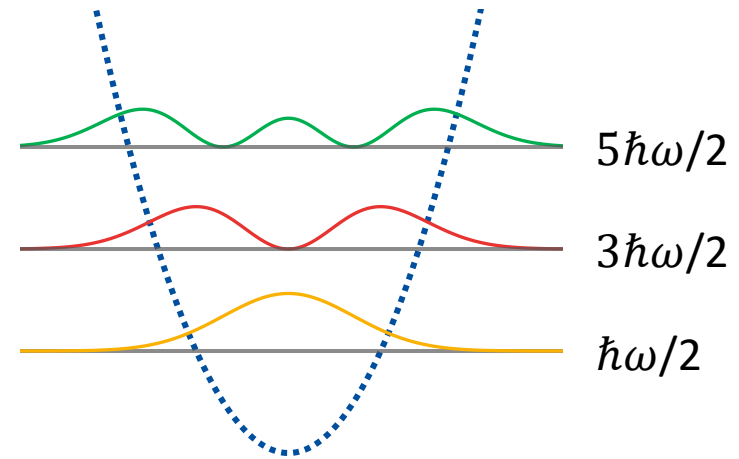

КАНОНИЧЕСКОЕ КВАНТОВАНИЕ: электромагнитное поле

Моды поля в резонаторе

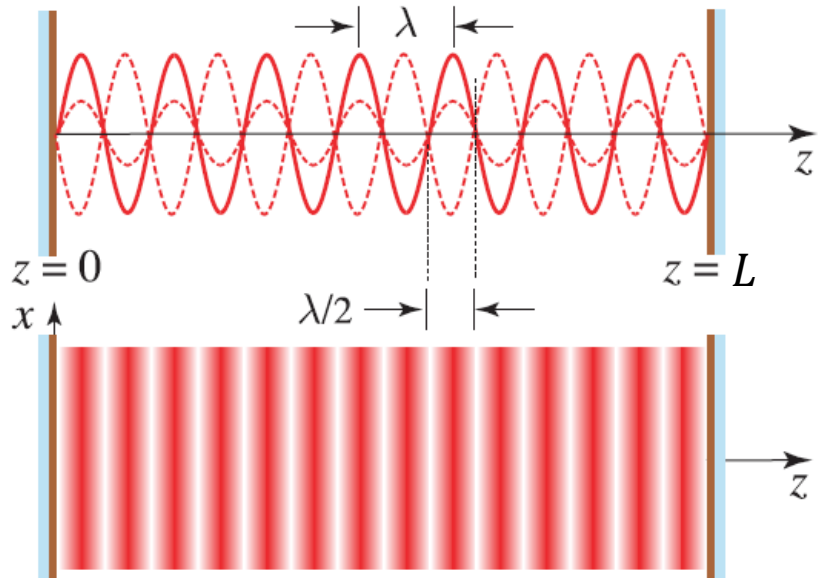

Мода – решение уравнений Максвелла, удовлетворяющее определенным граничным условиям. Можно говорить о *пространственных*, *пространственно-временных*, **поляризационных** модах и т.д.

$$\begin{aligned}\nabla \cdot \mathbf{D} &= \rho \\ \nabla \cdot \mathbf{B} &= 0 \\ \nabla \times \mathbf{E} &= -\frac{\partial \mathbf{B}}{\partial t} \\ \nabla \times \mathbf{H} &= \mathbf{j} + \frac{\partial \mathbf{D}}{\partial t}\end{aligned}$$



$$\begin{aligned}E_x(z, t) &= q(t) \sin(kz) \\ B_y(z, t) &= \frac{1}{kc^2} \dot{q}(t) \cos(kz)\end{aligned} \quad k = \frac{m\pi}{L}$$

$$\begin{aligned}H_F &= \frac{1}{2} \int_0^L dz \left\{ \varepsilon_0 |\mathbf{E}|^2 + \frac{1}{\mu_0} |\mathbf{B}|^2 \right\} \\ &= \frac{1}{2} \int_0^L dz \left\{ \varepsilon_0 q^2(t) \sin^2(kz) + \frac{1}{k^2 c^4 \mu_0} (\dot{q}(t))^2 \cos^2(kz) \right\}\end{aligned}$$



$$H_F = \frac{1}{2} \varepsilon_0 q^2(t) L + \frac{1}{4} \frac{\varepsilon_0}{\omega^2} L (\dot{q}(t))^2$$

КАНОНИЧЕСКОЕ КВАНТОВАНИЕ: электромагнитное поле

Моды поля в резонаторе

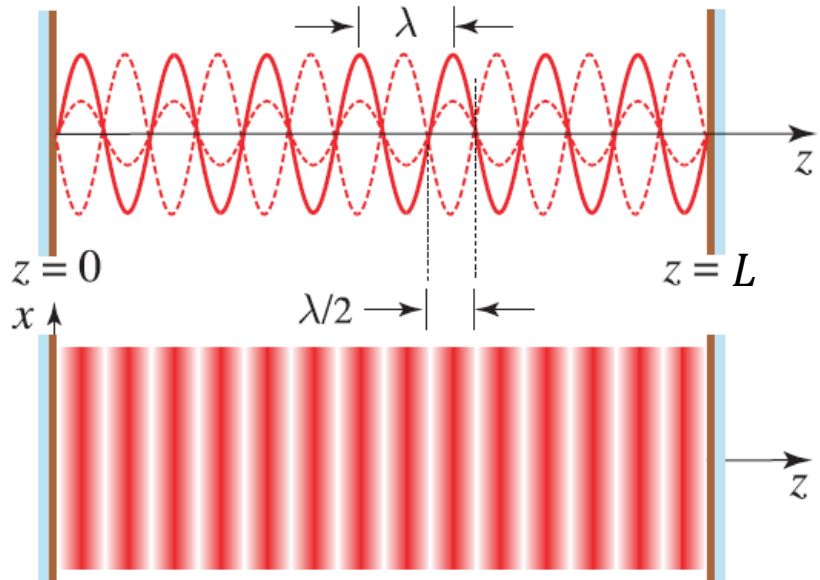

Мода – решение уравнений Максвелла, удовлетворяющее определенным граничным условиям. Можно говорить о пространственных, пространственно-временных, **поляризационных** модах и т.д.

$$H = \frac{m\dot{x}^2}{2} + \frac{\kappa x^2}{2} \longleftarrow H_F = \frac{1}{2} \varepsilon_0 q^2(t)L + \frac{1}{4} \frac{\varepsilon_0}{\omega^2} L(\dot{q}(t))^2$$

$$q = \sqrt{\frac{2m\omega^2}{\varepsilon_0 L}} x$$

$$\hat{X} = \hat{x} \sqrt{\frac{m\omega}{\hbar}}, \quad \hat{P} = \frac{\hat{p}}{\sqrt{m\omega\hbar}}$$

$$\hat{a} = \frac{1}{\sqrt{2}} (\hat{X} + i\hat{P}) \quad \hat{a}^\dagger = \frac{1}{\sqrt{2}} (\hat{X} - i\hat{P})$$

$$\hat{H}_F = \frac{1}{2} \hbar\omega (\hat{X}^2 + \hat{P}^2) = \hbar\omega \left(\hat{a}^\dagger \hat{a} + \frac{1}{2} \right)$$

КАНОНИЧЕСКОЕ КВАНТОВАНИЕ: электромагнитное поле

Моды поля в резонаторе

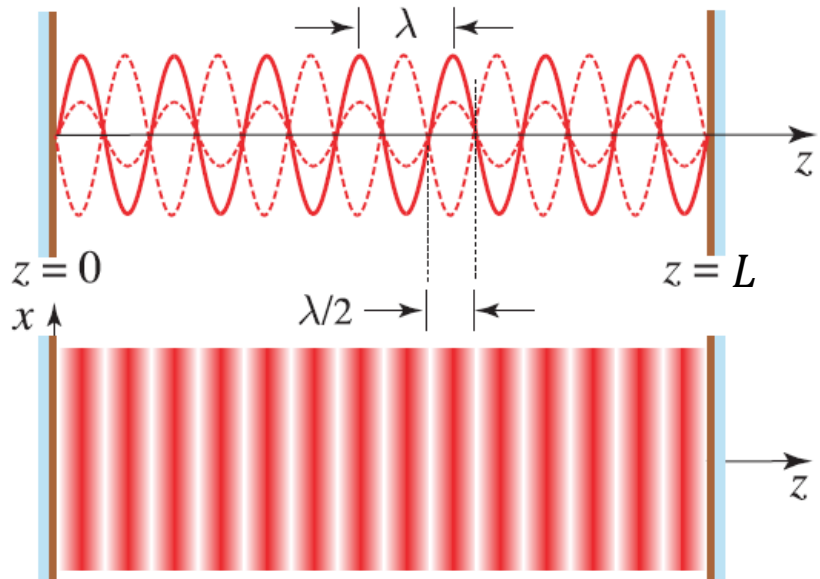

Мода – решение уравнений Максвелла, удовлетворяющее определенным граничным условиям. Можно говорить о *пространственных*, *пространственно-временных*, **поляризационных** модах и т.д.

$$\hat{H}_F = \frac{1}{2} \hbar \omega (\hat{X}^2 + \hat{P}^2) = \hbar \omega \left(\hat{a}^\dagger \hat{a} + \frac{1}{2} \right)$$

$|1\rangle$ – однофотонное (фоковское) состояние

$|2\rangle$ – двухфотонное (фоковское) состояние

...

$|0\rangle$ – вакуумное состояние

ФОТОН: ПЕРВИЧНОЕ vs КАНОНИЧЕСКОЕ КВАНТОВАНИЕ

Каноническое квантование

Квантовой системой является *мода* электромагнитной волны

Фотон – *состояние* моды;
фотоны «заполняют» моду,
как кубики сахара – сахарницу



Первичное квантование

Квантовой системой является сам квант энергии поля рассматриваемой моды

Фотон – безмассовая *частица*, движущаяся со скоростью света

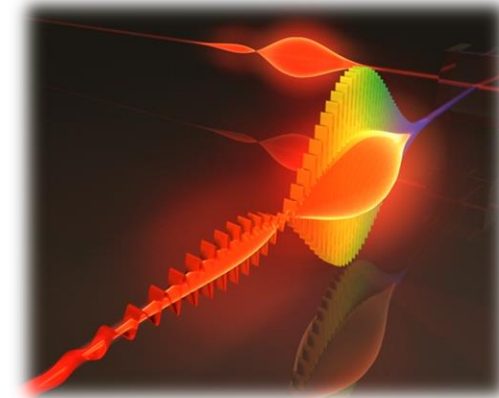

LIGHT POLARIZATION

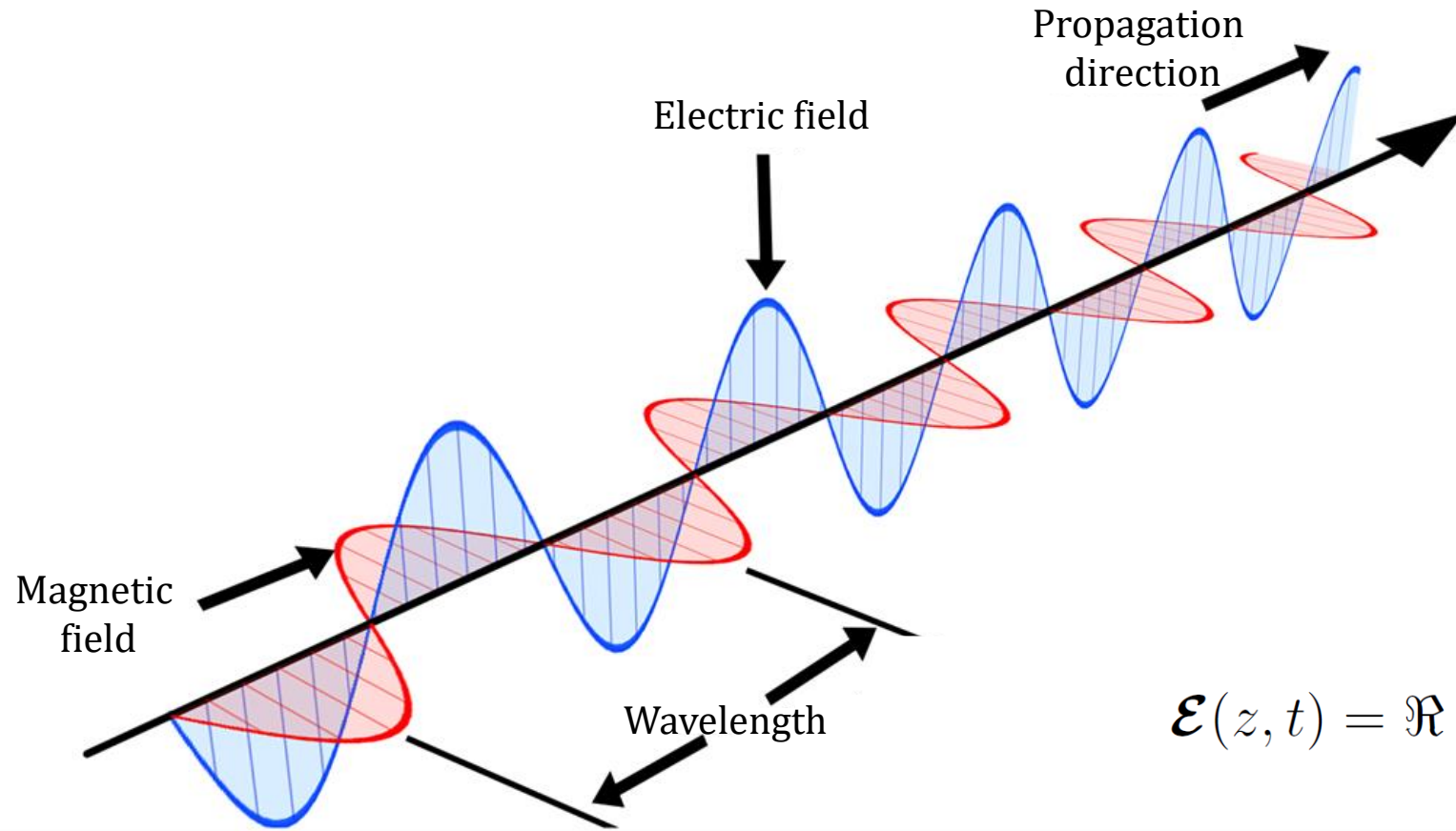

$$\mathcal{E}(z, t) = A_H \cos(\omega t - kz + \varphi_H) \mathbf{e}_x + A_V \cos(\omega t - kz + \varphi_V) \mathbf{e}_y,$$

or

$$\mathcal{E}(z, t) = \Re \left[(A_H e^{i\varphi_H} \mathbf{e}_x + A_V e^{i\varphi_V} \mathbf{e}_y) e^{i\omega t - ikz} \right]$$

POLARIZATION STATES: linear polarization

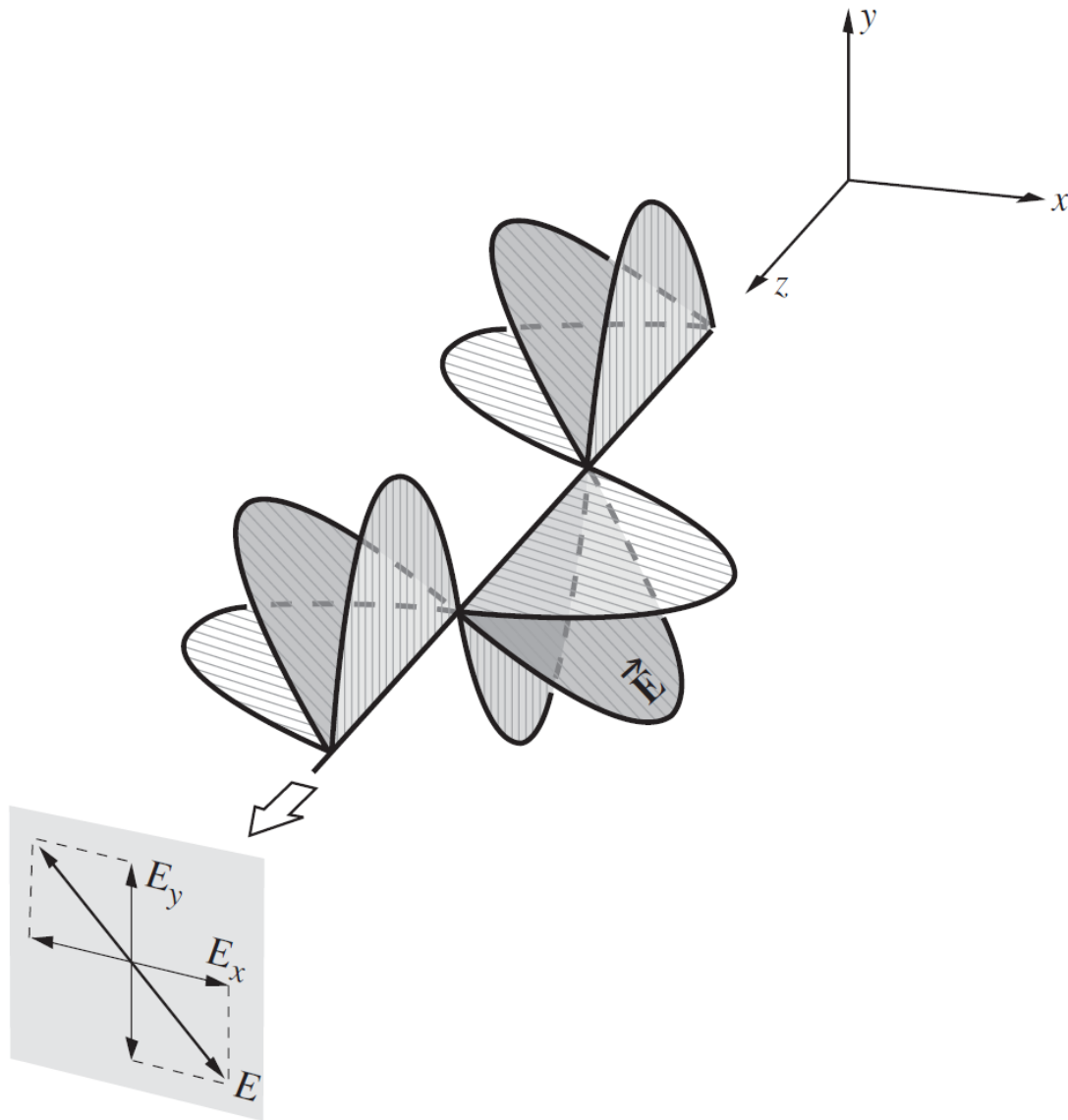

$$\mathcal{E}_H = A_H \cos(\omega t - kz + \varphi_H)$$

$$\mathcal{E}_V = A_V \cos(\omega t - kz + \varphi_V)$$

$$\delta = \varphi_V - \varphi_H$$

$$\delta = 0 \quad \text{or} \quad \delta = \pi$$

$$\tan(\theta) = \pm A_V / A_H$$

POLARIZATION STATES: circular polarization

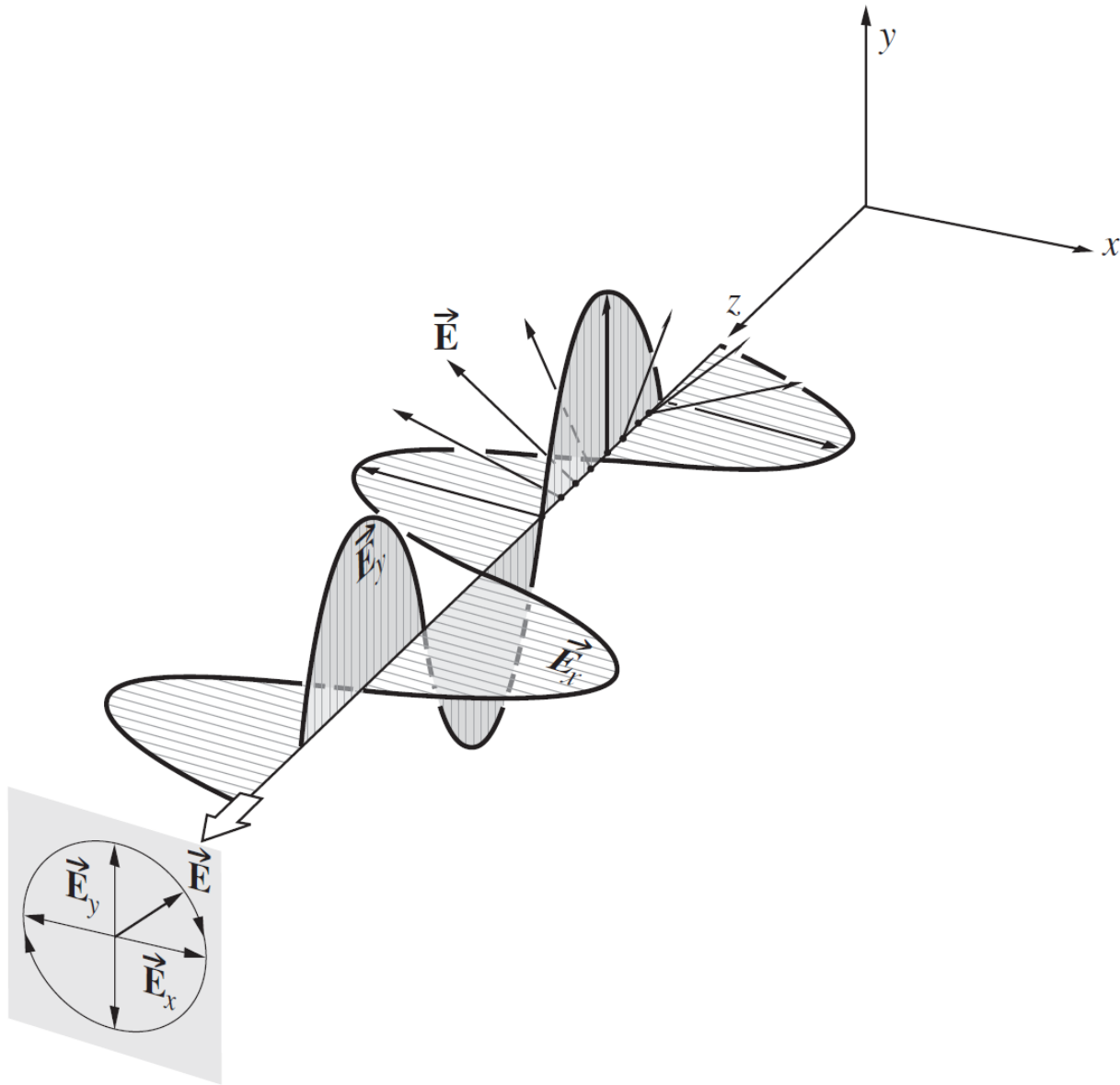

$$\mathcal{E}_H = A_H \cos(\omega t - kz + \varphi_H)$$

$$\mathcal{E}_V = A_V \cos(\omega t - kz + \varphi_V)$$

$$\delta = \varphi_V - \varphi_H$$

$$\delta = \pm\pi/2 \quad A_H = A_V$$

POLARIZATION STATES: elliptical polarization

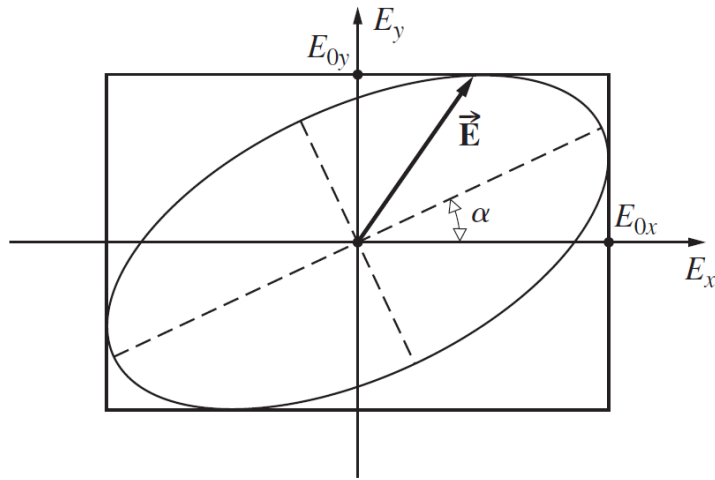

$$\mathcal{E}_H = A_H \cos(\omega t - kz + \varphi_H)$$

$$\mathcal{E}_V = A_V \cos(\omega t - kz + \varphi_V)$$

$$\delta = \varphi_V - \varphi_H$$

Left-handed

Right-handed

\vec{E}_y leads \vec{E}_x by:

2π

$7\pi/4$

$3\pi/2$

$5\pi/4$

π

$3\pi/4$

$\pi/2$

$\pi/4$

0

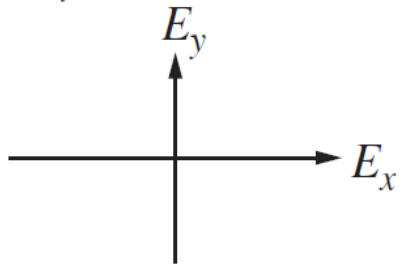

\vec{E}_x leads \vec{E}_y by:

0

$\pi/4$

$\pi/2$

$3\pi/4$

π

$5\pi/4$

$3\pi/2$

$7\pi/4$

2π

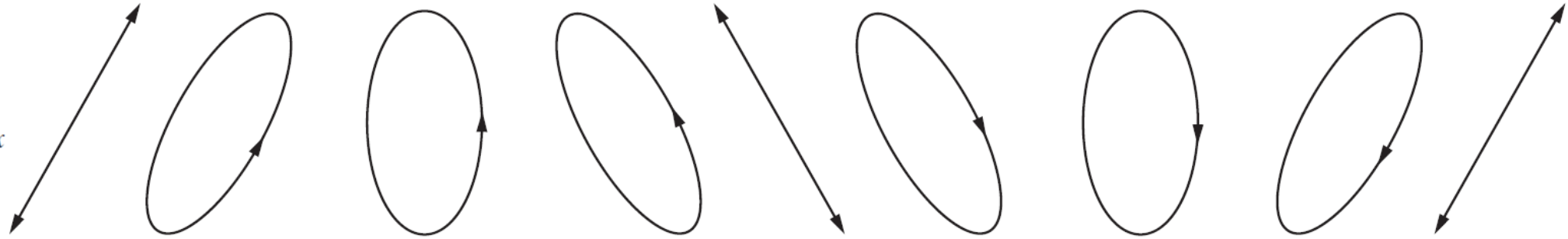

QUANTUM BASICS

1. What is a *Hilbert space*?
2. What is a *state vector* $|\psi\rangle$?
3. What is a *basis* in a Hilbert space? Orthonormal basis?
4. What is the difference between a state vector $|\psi\rangle$ and a *wave function* $\psi(\mathbf{r}, t)$?
5. What is a quantum-mechanical *operator*?
6. What is a *mixed* state? What is a density operator?

QUANTUM MEASUREMENT POSTULATE

Quantum measurements are experiments, whose aim is to obtain information about the quantum state of a system.

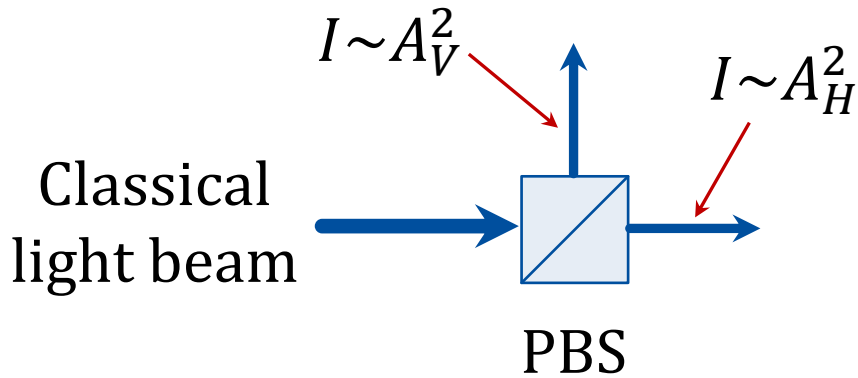

$$\mathbf{E} = \text{Re}[(A_H e^{i\varphi_H} \mathbf{e}_x + A_V e^{i\varphi_V} \mathbf{e}_y) e^{i\omega t}]$$

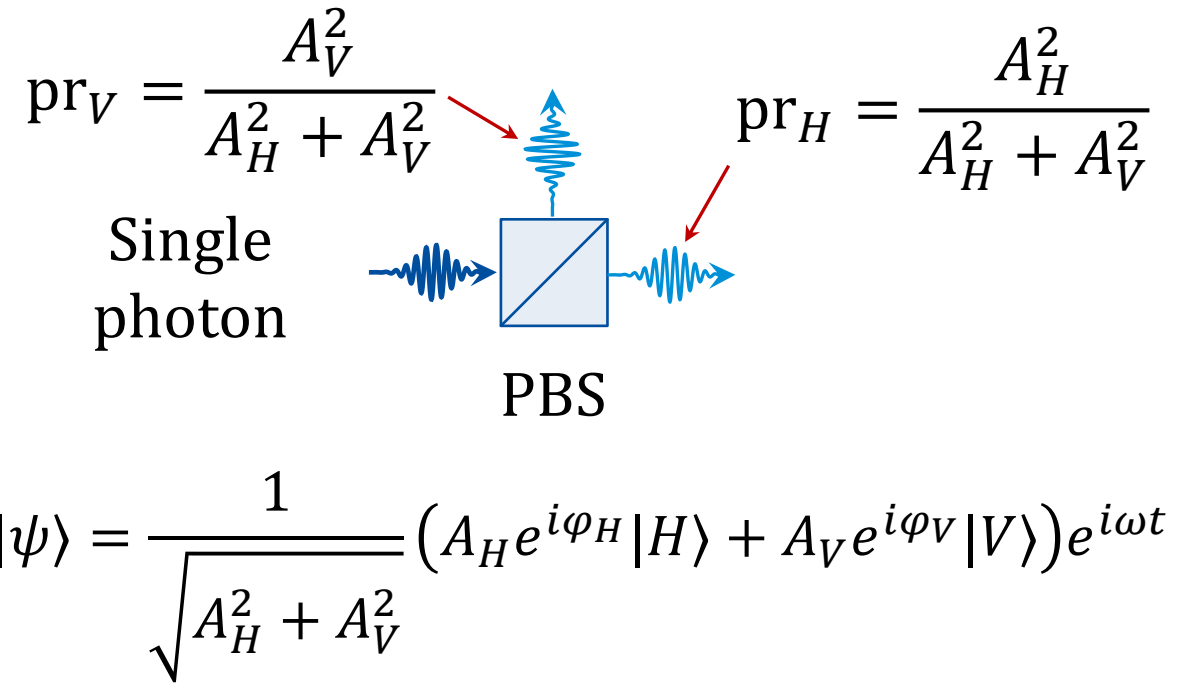

$$|\psi\rangle = \frac{1}{\sqrt{A_H^2 + A_V^2}} (A_H e^{i\varphi_H} |H\rangle + A_V e^{i\varphi_V} |V\rangle) e^{i\omega t}$$

The outcome of the measurement is **random**: $\text{pr}_H = |\langle H|\psi\rangle|^2$, $\text{pr}_V = |\langle V|\psi\rangle|^2$

QUANTUM MEASUREMENT POSTULATE

Choosing the path, the photon *changes its state*.

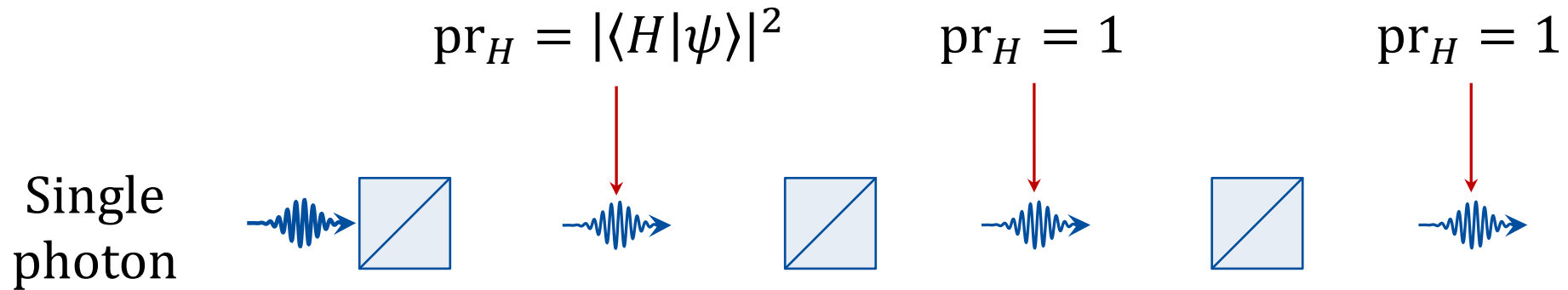

After the PBS, the photon state in the transmitted channel will become $|H\rangle$, and in the reflected channel $|V\rangle$. If we place a series of additional PBS's in the transmitted channel of the first PBS, the photon will be transmitted through all of these PBS's — there will be no further randomness.

QUANTUM MEASUREMENT POSTULATE

An idealized measurement apparatus is associated with some *orthonormal basis* $\{|b_i\rangle\}$. After the measurement, the apparatus will randomly point to one of the states $|b_i\rangle$ with probability

$$\text{pr}_i = |\langle b_i | \psi \rangle|^2 \quad - \text{Born's rule}$$

The system, if not destroyed, will then be *projected* onto state $|b_i\rangle$. Such a measurement is called a *projective measurement*.

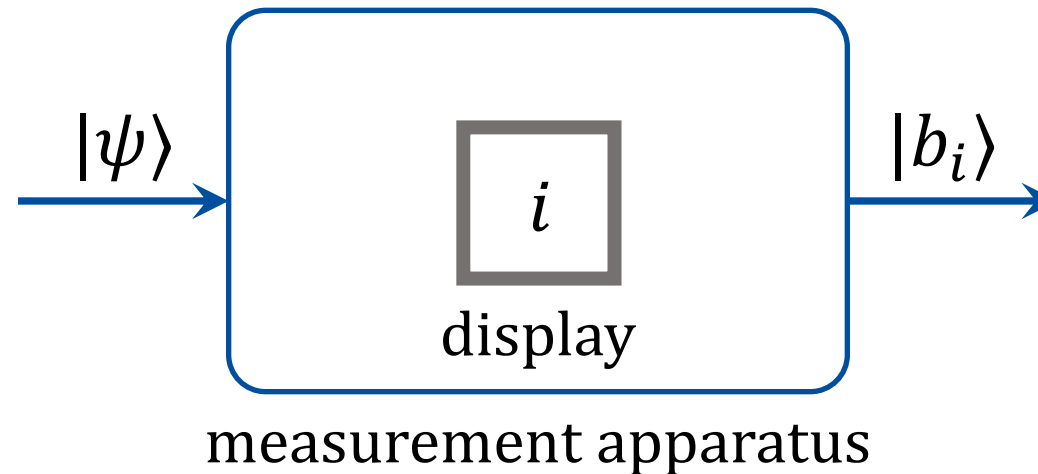

Let us accept quantum randomness as a postulate confirmed by numerous experiments

MEASUREMENT OF POLARIZATION STATES OF A PHOTON (PRELIMINARIES)

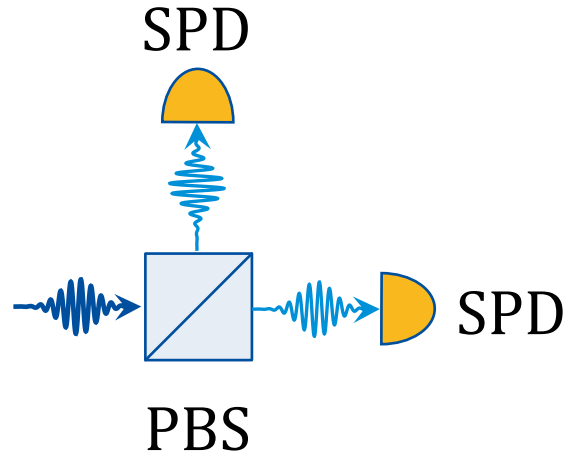

Single-photon detector

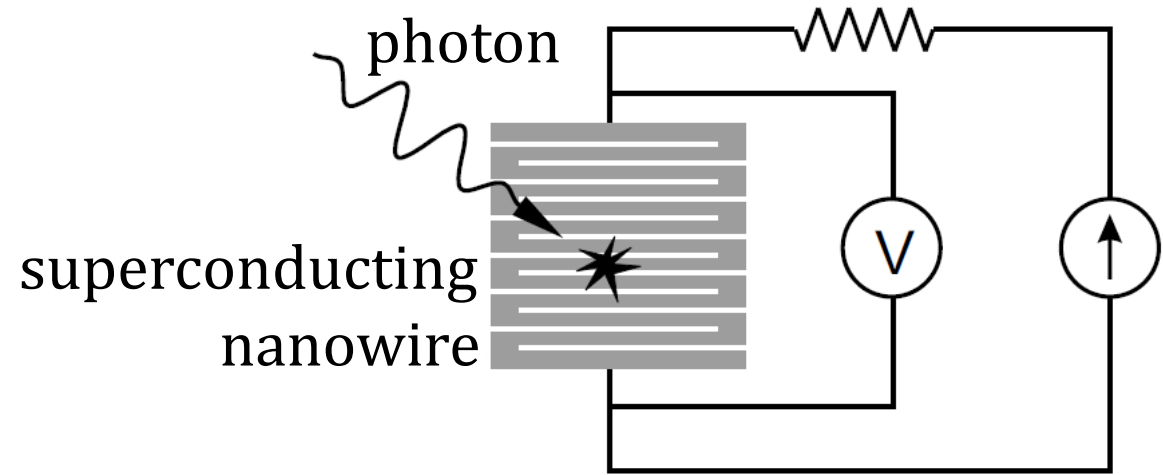

A photon detector is a device that converts a photon into a “click” — a macroscopic pulse of electric current or voltage.

MEASUREMENT OF POLARIZATION STATES OF A PHOTON (PRELIMINARIES)

Polarizing beamsplitters

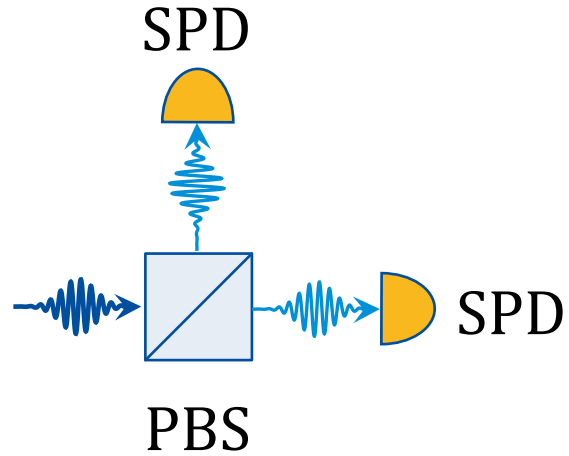

Wollaston prism

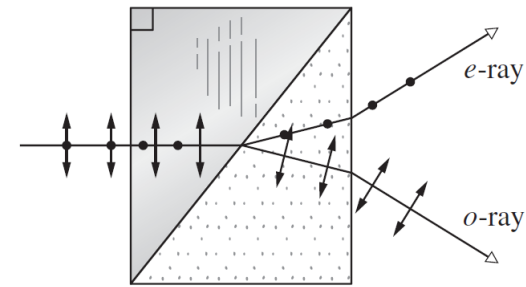

Cage cube



MEASUREMENT OF POLARIZATION STATES OF A PHOTON (PRELIMINARIES)

Wave plates

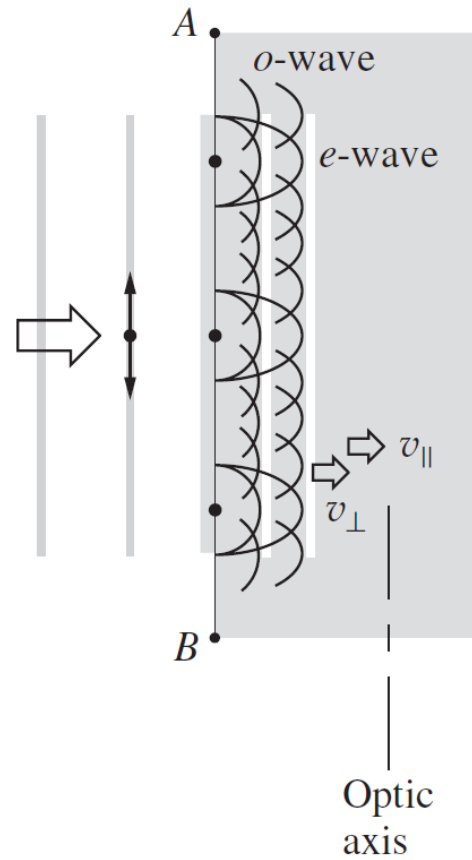
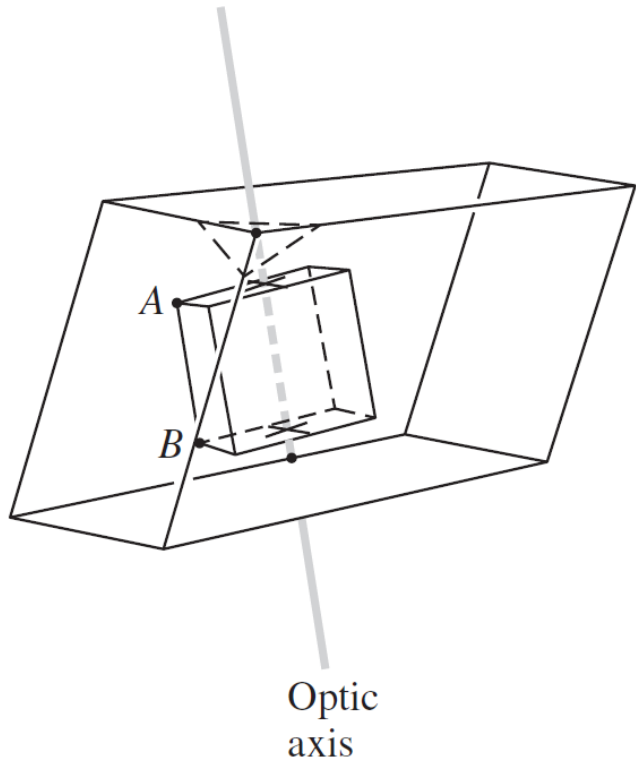

$$\Delta\varphi = \frac{2\pi}{\lambda_0} d(n_o - n_e)$$

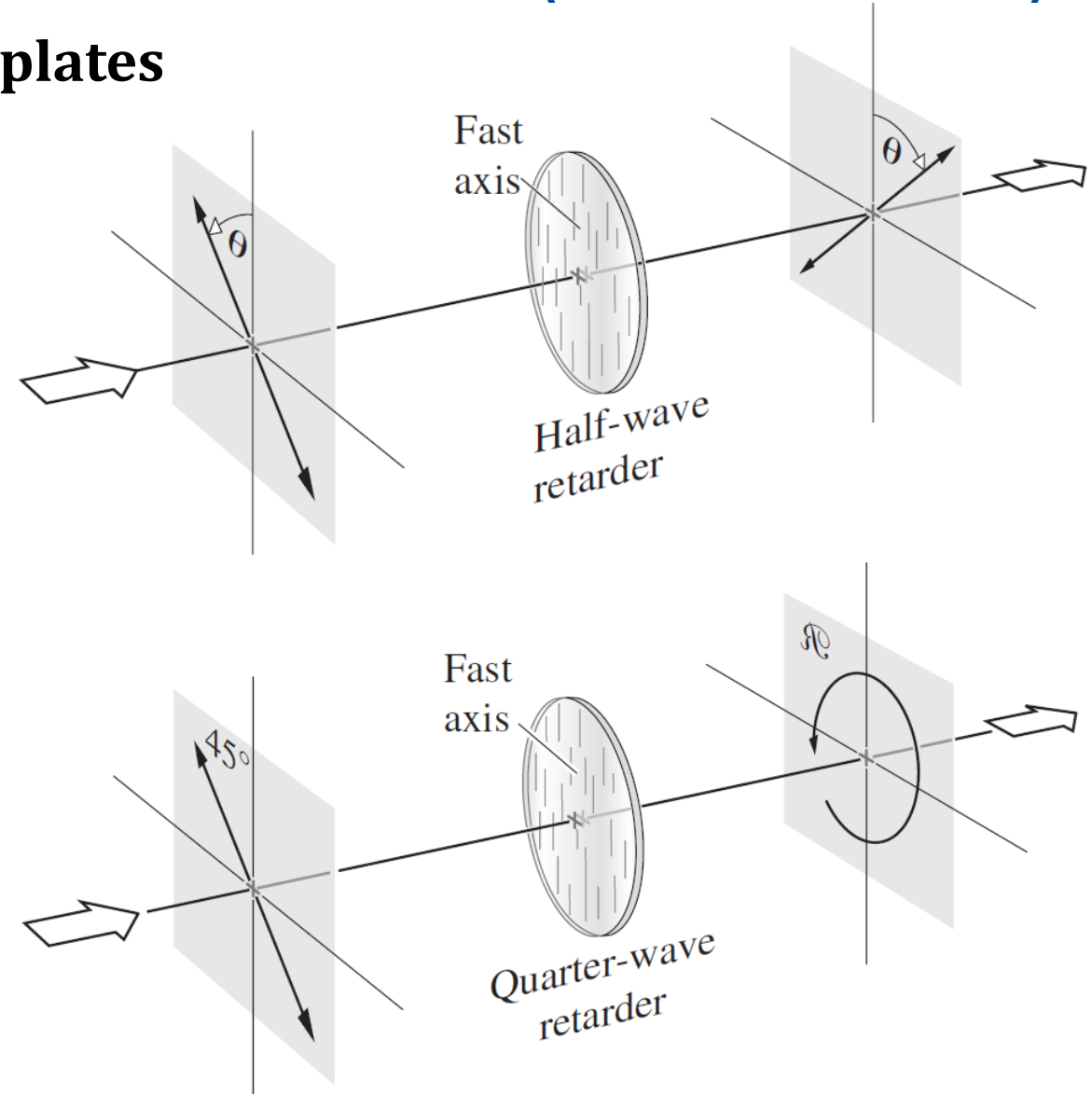

MEASUREMENT OF POLARIZATION STATES OF A PHOTON

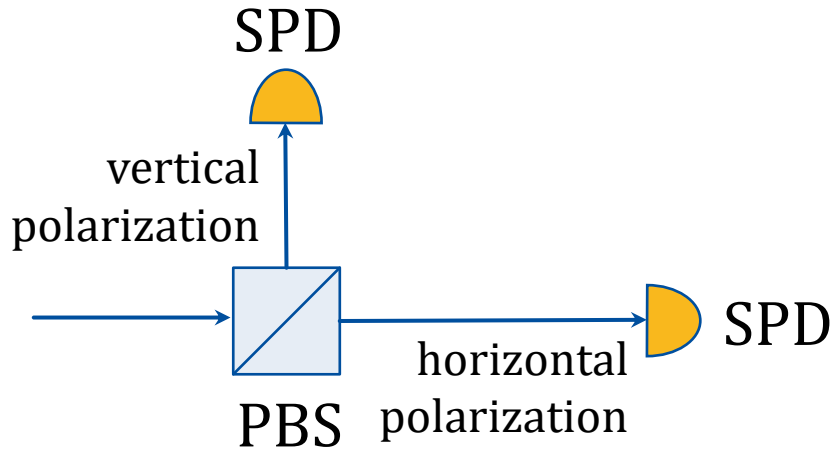

$$\{|H\rangle, |V\rangle\}$$

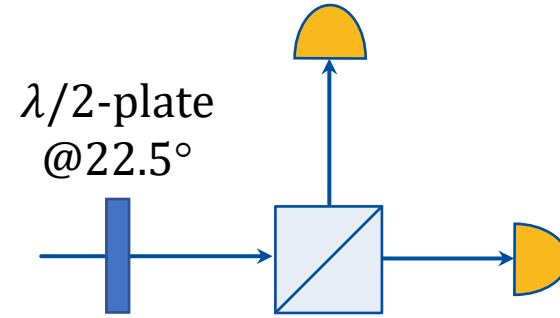

$$\{|+\rangle, |-\rangle\}$$

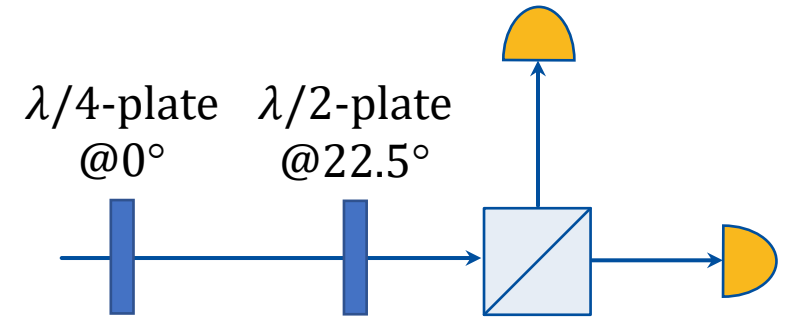

$$\{|L\rangle, |R\rangle\}$$

$$\left\{ \begin{aligned} |+\rangle &= \frac{1}{\sqrt{2}} (|H\rangle + |V\rangle) \\ |-\rangle &= \frac{1}{\sqrt{2}} (|H\rangle - |V\rangle) \end{aligned} \right\}$$

$$\left\{ \begin{aligned} |L\rangle &= \frac{1}{\sqrt{2}} (|H\rangle - i|V\rangle) \\ |R\rangle &= \frac{1}{\sqrt{2}} (|H\rangle + i|V\rangle) \end{aligned} \right\}$$

MEASUREMENT OF POLARIZATION STATES OF A PHOTON

Exercise 1

Each of the states $|H\rangle$, $|V\rangle$, $|+\rangle$, $|-\rangle$, $|R\rangle$, $|L\rangle$ is measured in 1) canonical, 2) diagonal, 3) circular bases.

Find the probabilities of the possible outcomes for each case.

MEASUREMENT OF POLARIZATION STATES OF A PHOTON

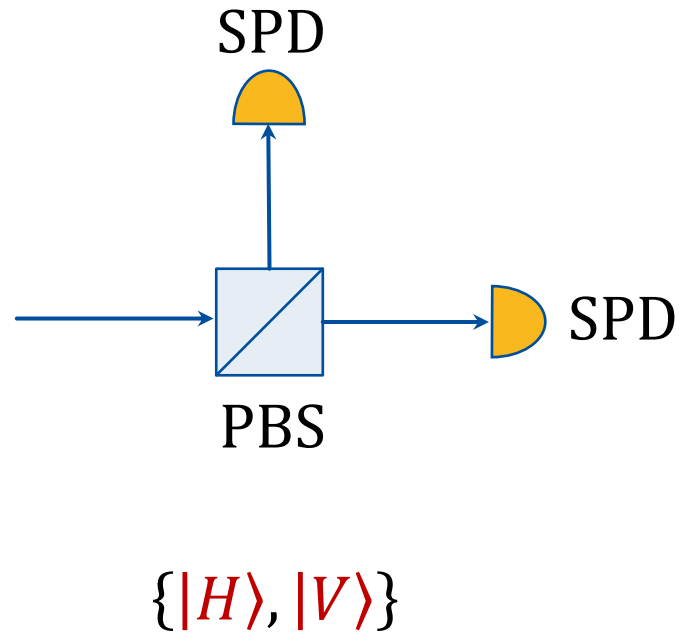

$$|\langle H|\pm\rangle|^2 = \frac{1}{2} |\langle H|H\rangle \pm \langle H|V\rangle|^2 = \frac{1}{2}$$

$$|\langle V|\pm\rangle|^2 = \frac{1}{2} |\langle V|H\rangle \pm \langle V|V\rangle|^2 = \frac{1}{2}$$

$$|\langle H|R/L\rangle|^2 = \frac{1}{2} |\langle H|H\rangle \pm i\langle H|V\rangle|^2 = \frac{1}{2}$$

$$|\langle V|R/L\rangle|^2 = \frac{1}{2} |\langle V|H\rangle \pm i\langle V|V\rangle|^2 = \frac{1}{2}$$

MEASUREMENT OF POLARIZATION STATES OF A PHOTON

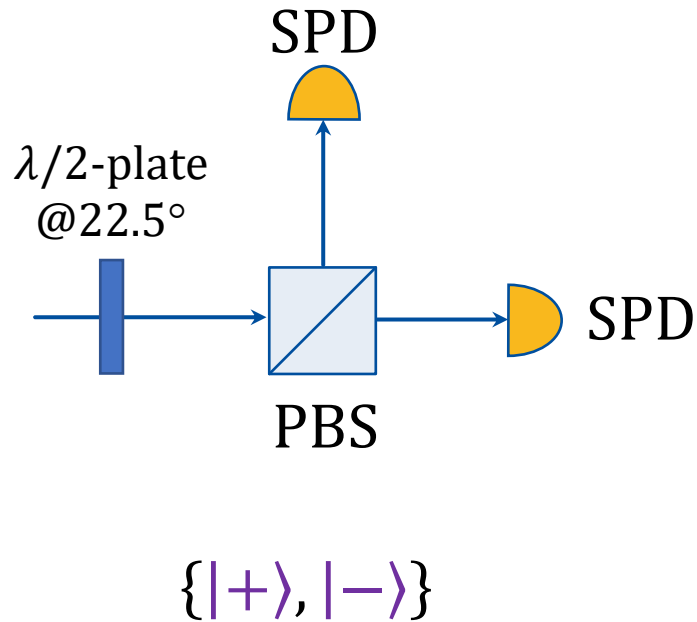

$$|\langle \pm | H \rangle|^2 = \frac{1}{2} |\langle H | H \rangle \pm \langle V | H \rangle|^2 = \frac{1}{2}$$

$$|\langle \pm | V \rangle|^2 = \frac{1}{2} |\langle H | H \rangle \pm \langle H | V \rangle|^2 = \frac{1}{2}$$

$$|\langle \pm | R \rangle|^2 = \frac{1}{4} |\langle H | H \rangle + i \langle H | V \rangle \pm \langle V | H \rangle \pm i \langle V | V \rangle|^2 = \frac{1}{2}$$

$$|\langle \pm | L \rangle|^2 = \frac{1}{4} |\langle H | H \rangle - i \langle H | V \rangle \pm \langle V | H \rangle \mp i \langle V | V \rangle|^2 = \frac{1}{2}$$

MEASUREMENT OF POLARIZATION STATES OF A PHOTON

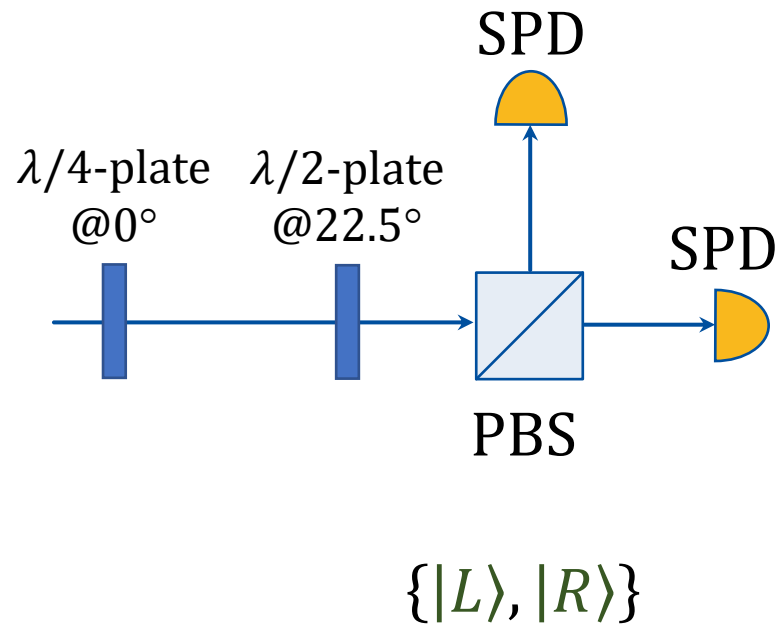

$$|\langle R|H/V\rangle|^2 = \frac{1}{2} |\langle H|H/V\rangle + i\langle V|H/V\rangle|^2 = \frac{1}{2}$$

$$|\langle L|H/V\rangle|^2 = \frac{1}{2} |\langle H|H/V\rangle - i\langle V|H/V\rangle|^2 = \frac{1}{2}$$

$$|\langle R|\pm\rangle|^2 = \frac{1}{4} |\langle H|H\rangle + \langle H|V\rangle \pm i\langle V|H\rangle \pm i\langle V|V\rangle|^2 = \frac{1}{2}$$

$$|\langle L|\pm\rangle|^2 = \frac{1}{4} |\langle H|H\rangle \pm \langle H|V\rangle - i\langle V|H\rangle \mp i\langle V|V\rangle|^2 = \frac{1}{2}$$

MEASUREMENT OF POLARIZATION STATES OF A PHOTON

Exercise 2

Propose a scheme for a quantum measurement in the basis $\{|\theta\rangle, |\frac{\pi}{2} + \theta\rangle\}$.

Hint:

Such a scheme should transform the state $|\theta\rangle$ into $|H\rangle$, and the state $|\frac{\pi}{2} + \theta\rangle$ into $|V\rangle$.

MEASUREMENT OF POLARIZATION STATES OF A PHOTON

Polarization rotation by a $\lambda/2$ plate

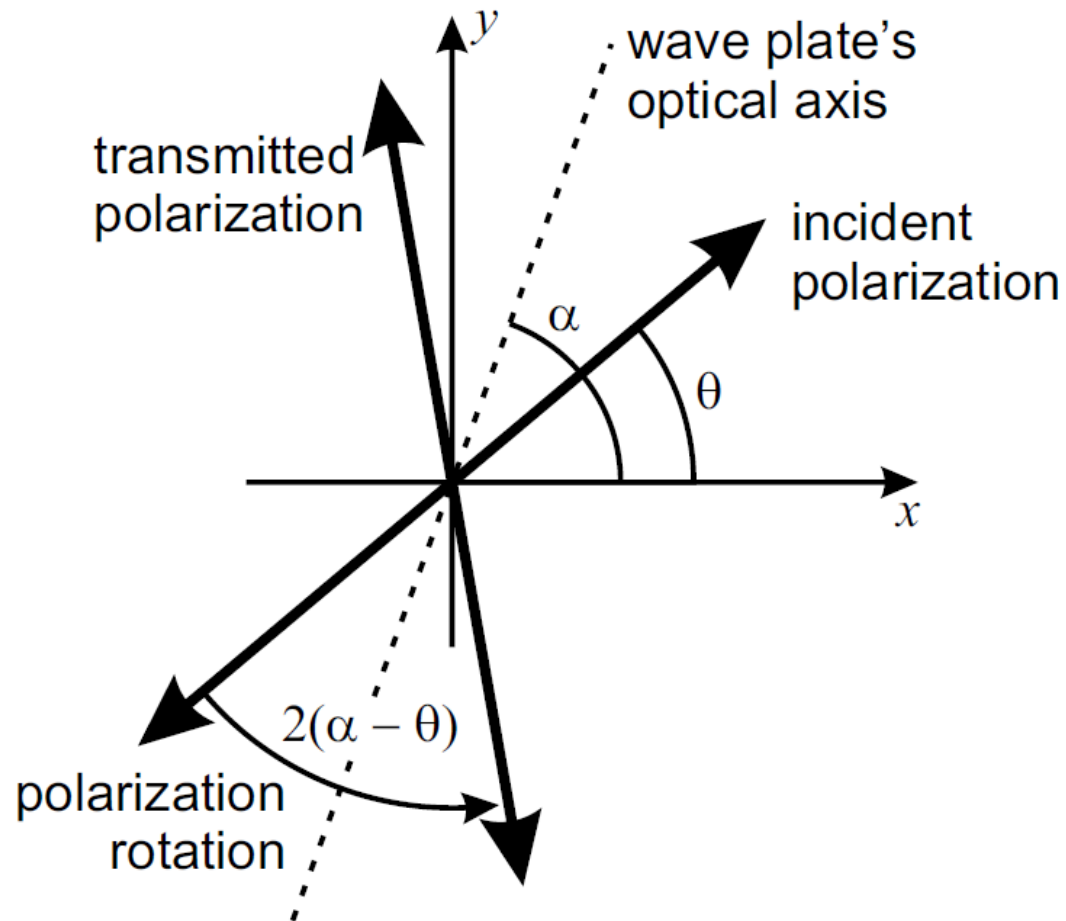

The half-wave plate “flips” the polarization pattern around the vertical (or horizontal) axis akin to a mirror.

What is the angle between the new polarization and the x-axis?

One can see that it is

$$2(\alpha - \theta) + \theta = 2\alpha - \theta$$

MEASUREMENT OF POLARIZATION STATES OF A PHOTON

$$2(\alpha - \theta) + \theta = 2\alpha - \theta$$

If $\alpha = \frac{\theta}{2}$, then

$$\theta \rightarrow 2\alpha - \theta = 2\left(\frac{\theta}{2}\right) - \theta = 0,$$

i.e., $|\theta\rangle \rightarrow |H\rangle$

$$\frac{\pi}{2} + \theta \rightarrow 2\alpha - \theta - \frac{\pi}{2} = 2\left(\frac{\theta}{2}\right) - \theta - \frac{\pi}{2} = -\frac{\pi}{2},$$

i.e., $|\frac{\pi}{2} + \theta\rangle \rightarrow |V\rangle$

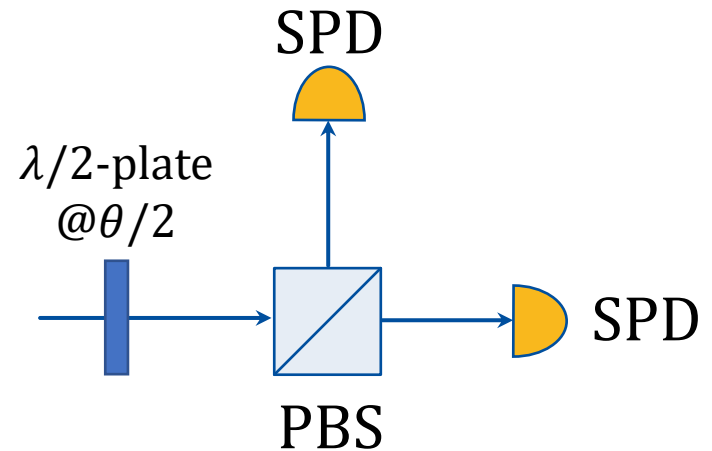

$$\left\{ |\theta\rangle, \left| \frac{\pi}{2} + \theta \right\rangle \right\}$$

MEASUREMENT OF POLARIZATION STATES OF A PHOTON

Exercise 3

A photon in state $|\psi\rangle = (|H\rangle + e^{i\varphi}|V\rangle)/\sqrt{2}$ is measured in the diagonal basis. Find the probability of each outcome as a function of φ .

MEASUREMENT OF POLARIZATION STATES OF A PHOTON

Exercise 3

A photon in state $|\psi\rangle = (|H\rangle + e^{i\varphi}|V\rangle)/\sqrt{2}$ is measured in the diagonal basis. Find the probability of each outcome as a function of φ .

$$\begin{aligned} \frac{1}{2} |\langle + | (|H\rangle + e^{i\varphi}|V\rangle) \rangle|^2 &= \frac{1}{4} |\langle H|H\rangle + e^{i\varphi}\langle H|V\rangle + \langle V|H\rangle + e^{i\varphi}\langle V|V\rangle|^2 = \\ &= \frac{1}{4} |1 + e^{i\varphi}|^2 = \cos^2 \frac{\varphi}{2} \end{aligned}$$

$$\begin{aligned} \frac{1}{2} |\langle - | (|H\rangle + e^{i\varphi}|V\rangle) \rangle|^2 &= \frac{1}{4} |\langle H|H\rangle + e^{i\varphi}\langle H|V\rangle - \langle V|H\rangle - e^{i\varphi}\langle V|V\rangle|^2 = \\ &= \frac{1}{4} |1 - e^{i\varphi}|^2 = \sin^2 \frac{\varphi}{2} \end{aligned}$$

MEASUREMENT OF POLARIZATION STATES OF A PHOTON

Exercise 4 (tomography of the polarization state)

A photon in state $|\psi\rangle = (r_H|H\rangle + e^{i\varphi}r_V|V\rangle)$ is measured in the rectilinear, diagonal and circular basis yielding $pr_H, pr_V, pr_+, pr_-, pr_R, pr_L$. Is it enough to perform a tomography of $|\psi\rangle$ (to determine r_H, r_V and φ)? Prove it.

MEASUREMENT OF POLARIZATION STATES OF A PHOTON

Exercise 4 (tomography of the polarization state)

In a rectilinear basis: $\text{pr}_H = |\langle H|\psi\rangle|^2 = \left| (1 \ 0) \begin{pmatrix} r_H \\ r_V e^{i\varphi} \end{pmatrix} \right|^2 = r_H^2$, wherein

$$r_H = \sqrt{\text{pr}_H}; \quad r_V = \sqrt{1 - r_H^2} = \sqrt{1 - \text{pr}_H}$$

In a diagonal basis: $\text{pr}_+ = |\langle +|\psi\rangle|^2 = \left| \frac{1}{\sqrt{2}} (1 \ 1) \begin{pmatrix} r_H \\ r_V e^{i\varphi} \end{pmatrix} \right|^2 = \frac{1}{2} + r_H r_V \cos \varphi$

In a circular basis: $\text{pr}_R = |\langle L|\psi\rangle|^2 = \left| \frac{1}{\sqrt{2}} (1 \ -i) \begin{pmatrix} r_H \\ r_V e^{i\varphi} \end{pmatrix} \right|^2 = \frac{1}{2} + r_H r_V \sin \varphi$

PROJECTION OPERATORS

The projective measurement does not necessarily destroy the quantum state. The Measurement Postulate says in this case that the measurement transforms $|\psi\rangle$ into one of the $|b_i\rangle$ with the probability $\text{pr}_i = |\langle b_i|\psi\rangle|^2$. This can be formulated in terms of a projection operator $\hat{\Pi}_i = |b_i\rangle\langle b_i|$:

$$|\psi\rangle \rightarrow \hat{\Pi}_i|\psi\rangle = (|b_i\rangle\langle b_i|)|\psi\rangle = \langle b_i|\psi\rangle|b_i\rangle$$

Example

A non-destructive measurement of the state $|\psi\rangle = (2|H\rangle + |V\rangle)/\sqrt{5}$ in the canonical basis generates the following *unnormalized* states:

$$|\psi'_H\rangle = \hat{\Pi}_H|\psi\rangle = |H\rangle\langle H|\psi\rangle = 2|H\rangle/\sqrt{5}$$

$$|\psi'_V\rangle = \hat{\Pi}_V|\psi\rangle = |V\rangle\langle V|\psi\rangle = |V\rangle/\sqrt{5}$$

MEASUREMENT OF MIXED STATES

The projective measurement for the density matrix:

$$\hat{\rho} = \sum_n p_n |\psi_n\rangle\langle\psi_n| \rightarrow \sum_n p_n \hat{\Pi}_i |\psi_n\rangle\langle\psi_n| \hat{\Pi}_i = \hat{\Pi}_i \hat{\rho} \hat{\Pi}_i$$

For each component $|\psi_n\rangle$ of the ensemble, the (conditional) probability to obtain $|b_i\rangle$ is $\text{pr}_{i|n} = |\langle b_i | \psi_n \rangle|^2$, so the probability to measure $|b_i\rangle$ for the density matrix is

$$\begin{aligned} \text{pr}_i &= \sum_n p_n \text{pr}_{i|n} = \sum_n p_n |\langle b_i | \psi_n \rangle|^2 = \sum_n p_n \langle b_i | \psi_n \rangle \langle \psi_n | b_i \rangle = \langle b_i | \hat{\rho} | b_i \rangle \\ &= \text{Tr}[\hat{\rho} |b_i\rangle\langle b_i|] = \text{Tr}[\hat{\rho} \hat{\Pi}_i] \end{aligned}$$

MEASUREMENT OF MIXED STATES

Exercise 5

A quantum state is represented by a density matrix $\hat{\rho}$ in the basis $\{|b_i\rangle\}$. Suppose this state is measured in the same basis. The measurement is nondestructive, but its outcome is unknown to us. Find the density matrix after the measurement.

MEASUREMENT OF MIXED STATES

Exercise 5

A quantum state is represented by a density matrix $\hat{\rho}$ in the basis $\{|b_i\rangle\}$. Suppose this state is measured in the same basis. The measurement is nondestructive, but its outcome is unknown to us. Find the density matrix after the measurement.

If the outcome is $|b_i\rangle$, then the density matrix is

$$\hat{\rho}_i = \hat{\Pi}_i \hat{\rho} \hat{\Pi}_i = |b_i\rangle \langle b_i | \hat{\rho} | b_i\rangle \langle b_i| = \rho_{ii} |b_i\rangle \langle b_i|$$

If the outcome is unknown, then the density matrix is the ensemble:

$$\hat{\rho}_{\text{after}} = \sum_i \rho_{ii} |b_i\rangle \langle b_i| \cong \begin{pmatrix} \rho_{11} & \cdots & 0 \\ \vdots & \ddots & \vdots \\ 0 & \cdots & \rho_{NN} \end{pmatrix}$$

GENERALIZED QUANTUM MEASUREMENTS

Measurement of polarization states with a non-ideal PBS

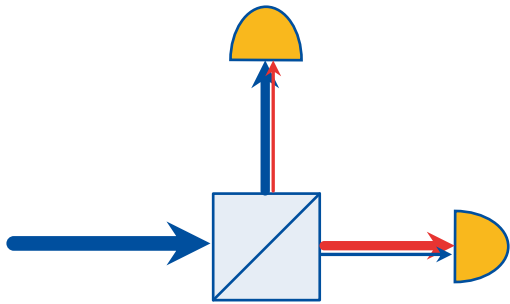

Example of a scrambler matrix:

$$\begin{pmatrix} \mu_{HH} & \mu_{HV} \\ \mu_{VH} & \mu_{VV} \end{pmatrix} = \begin{pmatrix} 3/4 & 1/3 \\ 1/4 & 2/3 \end{pmatrix};$$

μ_{ji} – probability that for the state $|b_i\rangle$ the scrambler chooses the output j

Model of a realistic measurement device

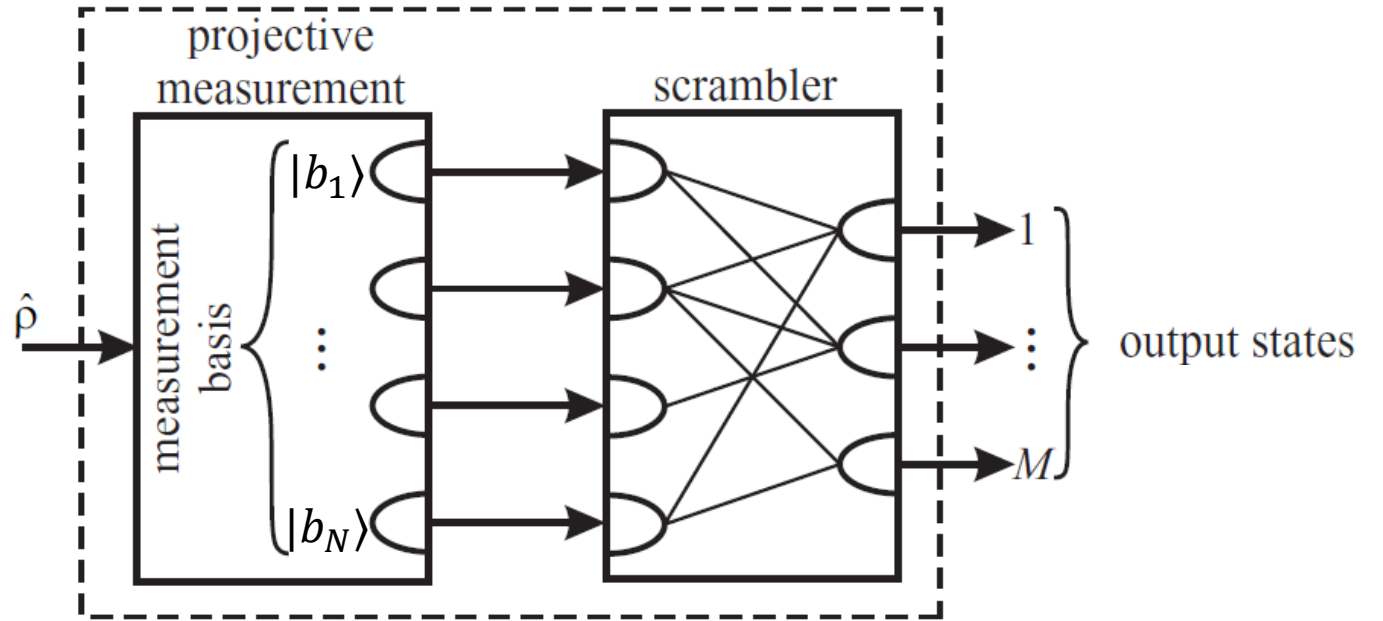

GENERALIZED QUANTUM MEASUREMENTS

Exercise 6

A non-discriminating detector has the following properties:

- There are no dark counts.
- Each incoming photon generates an avalanche with probability η (the detector's quantum efficiency). If at least one avalanche is present, the detector's circuit produces a "click".

Model this detector as a projective measurement in the photon number basis, followed by a scrambler, and calculate the scrambler matrix.

GENERALIZED QUANTUM MEASUREMENTS

$$\begin{pmatrix} |0\rangle \\ |1\rangle \\ \vdots \\ |n\rangle \\ \vdots \end{pmatrix} \rightarrow \text{scrambler} \rightarrow \begin{pmatrix} \text{no click} \\ \text{click} \end{pmatrix}$$

Probability that there is no click: $(1 - \eta)^n$
Probability that there is a click: $1 - (1 - \eta)^n$

Scrambler matrix:

$$\begin{pmatrix} \mu_{\text{no click},0} & \mu_{\text{no click},1} & \cdots & \mu_{\text{no click},n} & \cdots \\ \mu_{\text{click},0} & \mu_{\text{click},1} & \cdots & \mu_{\text{click},n} & \cdots \end{pmatrix}$$

$$\mu_{\text{no click},n} = (1 - \eta)^n, \quad \mu_{\text{click},n} = 1 - (1 - \eta)^n$$

GENERALIZED QUANTUM MEASUREMENTS

The set of operators

$$\hat{F}_j = \sum_i \mu_{ji} |b_i\rangle\langle b_i|$$

each associated with the j -th output state of the detector is called **positive operator-valued measure (POVM)**.

A measurement described by a POVM is called a generalized measurement.

Example: POVM of non-discriminating detector

$$\hat{F}_{\text{no click}} = \sum_n (1 - \eta)^n |n\rangle\langle n|, \quad \hat{F}_{\text{click}} = \sum_n [1 - (1 - \eta)^n] |n\rangle\langle n|$$

GENERALIZED QUANTUM MEASUREMENTS OF MIXED STATES

When a quantum state $\hat{\rho}$ is measured by a detector described by some POVM $\{\hat{F}_j\}$, the probability of the j -th outcome is

$$\text{pr}_j = \sum_i \mu_{ji} \text{pr}_i = \text{Tr} \left[\sum_i \mu_{ji} \hat{\Pi}_i \hat{\rho} \right] = \text{Tr}[\hat{F}_j \hat{\rho}]$$